

Varenummer: 2303039241  
Beskrivelse: E+G Fast Spændegreb  
MF.80 p-M10x30

## Mål

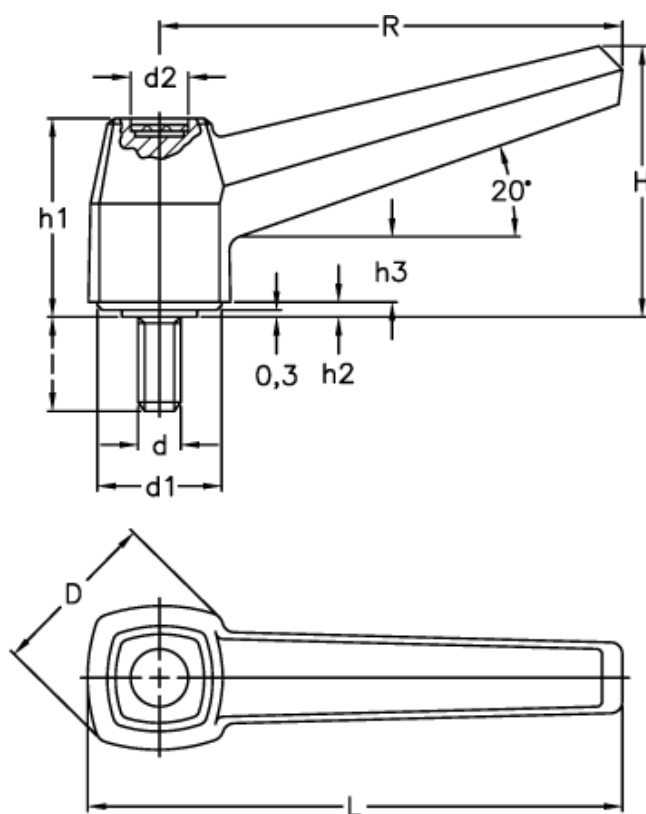

D = 28	I = 30
d1 = 18.5	L = 92
d2 = 11	R = 80
d 6g = M10	
H = 47	
h1 = 34	
h2 = 2.2	
h3 = 14	